

POWERSTAR Mobile Refuse Compactor

User's Manual



www.isuzutruckscn.com

POWERSTAR TRUCKS INDUSTRY CO., LIMITED

<http://www.isuzutruckscn.com/>

Preface

Thank you for purchasing POWERSTAR products. For better using your ISUZU garbage compactor truck, get the best operating performance, we strongly suggest that before the operation process you could read this manual instructions carefully, and to manipulate the program handily.

The manual detailed describes the performance of garbage compactor truck, structure, usage, precautions and maintenance of such knowledge. While showing details of the truck, both pictures and description will together help you get better understanding of how to use truck. Before the operation, the skilled operator should carefully read the contents of the manual.

After master the truck performance characteristics, methods of operation and precautions, then could start to operate this garbage truck. In order to ensure the staff turnover after the operation, and properly use of the truck. This manual book must be properly kept, shall not be lost and damage.

---POWERSTAR TRUCKS

www.isuzutruckscn.com

Contents

Chapter 1. General Description	4
Chapter 2, Main Technical Data.....	5
Chapter 3, Garbage Compactor Truck Structure Components	6
Chapter 4, Garbage Compactor Truck Working Principles	11
i ,How are the Garbage Compactor trucks working?	11
ii ,What is the main component for truck?	11
iii, How to operate garbage compactor trucks? (Very Important)	12
Chapter 5, Maintenance and Repair Instruction	21
Chapter 6, Troubleshooting	25

www.isuzutruckscn.com

Chapter 1. General Description

*POWERSTAR TRUCKS Garbage Compactor Truck based on type II ISUZU 4*2 Left Hand Drive chassis, Compactor body capacity could up to 12,000liters, which equipped with Electric Control System and Hydraulic Joystick Control System, mainly used for garbage collection and transportation, and the working aerial can be city street, factory, community and other areas of need.*

The vehicle designed to fully rely on the advantages of the original of ISUZU brand chassis, fully consider the product's convenience and reliability, also the chassis ISUZU technology features. The garbage compactor body material is international standard carbon steel, both internal and external with anti-rust painting, which can effective to avoid rusting. As for compactor body capacity is 12CBM and safety enough to collecting & transporting waste on customer requirement.

The ISUZU 4x2 Garbage Compactor Truck equipped with Siemens PLC system, multi-function garbage compression system, side climbing ladder, Electric control boxes in cabin and rear of hopper, rear tilting device to collecting garbage from international standard 240L bins, two units waste water collection tank can efficiently prevent second pollution during transportation. Cab for the single-row Comfortable seat, nice driving feeling. Therefore, the vehicle is an ideal Fuel Tanker Truck mainly for oil transportation & refueling function.



(Preview for your ISUZU 12CBM Garbage Compactor Truck)

Chapter 2, Main Technical Data

Basic parameter:

Items		12CBM ISUZU Garbage Compactor Truck
S I Z E	Outer Dimension (L×W×H) (mm)	8700*2500*3300
	Wheelbase (mm)	4500
Kerb Weight (kg)		9100
G E A R	Gearbox brand	ISUZU MLD
	Model	6-shift gearbox
	Type	Manual
Cab capacity (includes driver)		2+1
E N G I N	Brand	ISUZU
	Model	6HK1-TCNG40
	Type	Six cylinder inline, four stroke, water-cool, turbocharged Inter-cooling, diesel
	Rating Power (kW/HP)	177 / 240

Note: 1. We keeps the right to revise the parameters on the list above.

Garbage Body basic parameter list

Items		Parameter	
Garbage Body	Capacity (CBM)	12	
	Material	Standard Carbon Steel	
	Painting	Internal	With anti-rust painting
		External	White painting as required
	Control System	Electric Control	Control Box in Cabin
		Hydraulic Control	Control Box two sides of hopper
	PLC	Behind of cabin at driver side	
	Hydraulic Cylinder quantity	Hopper	As standard
		Slide Plate	2
		Scraper	2
Tilting device		2	
Push Plate		2	

Chapter 3, Garbage Compactor Truck Structure Components

Overview for ISUZU 12CBM garbage compactor truck technical drawing:

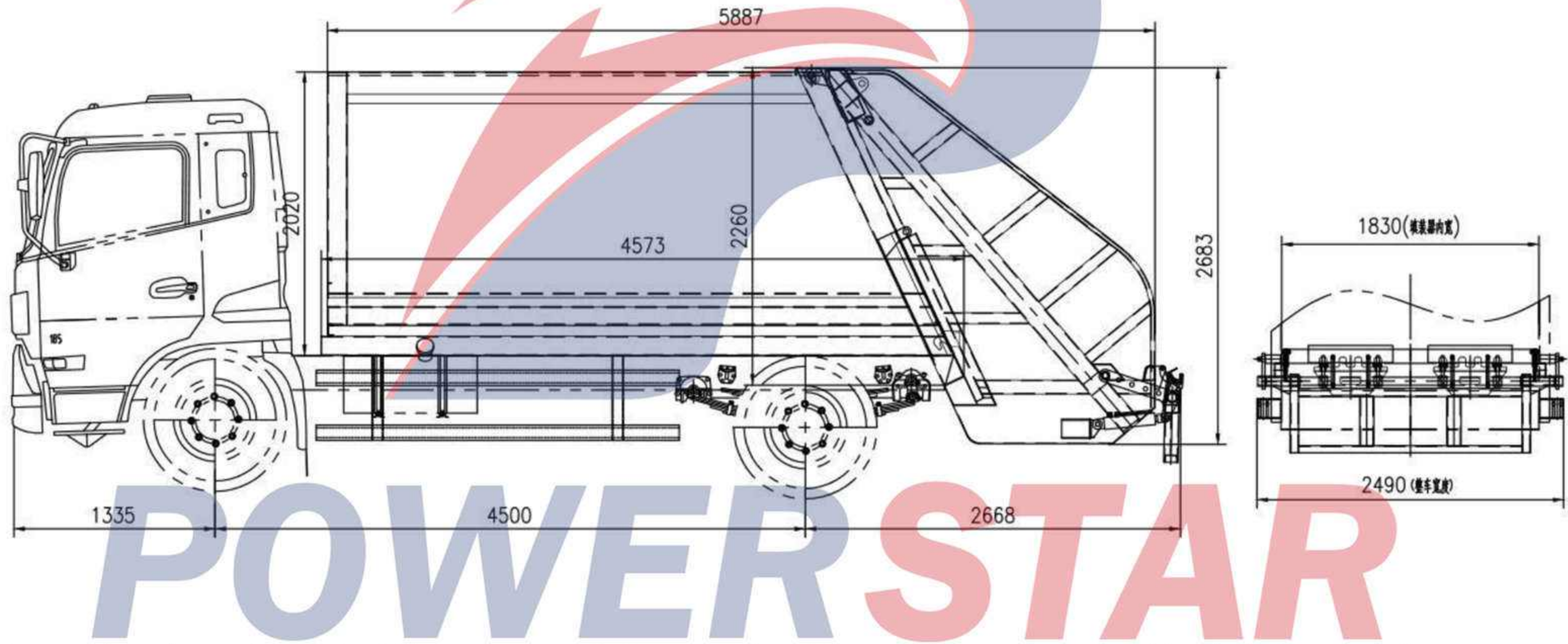

Above drawing show that there are safety-guards at two sides; at rear of tank is hopper for garbage collection; in front of the tank equipped climbing ladder. Below figure help you better understanding the structure of the garbage truck:

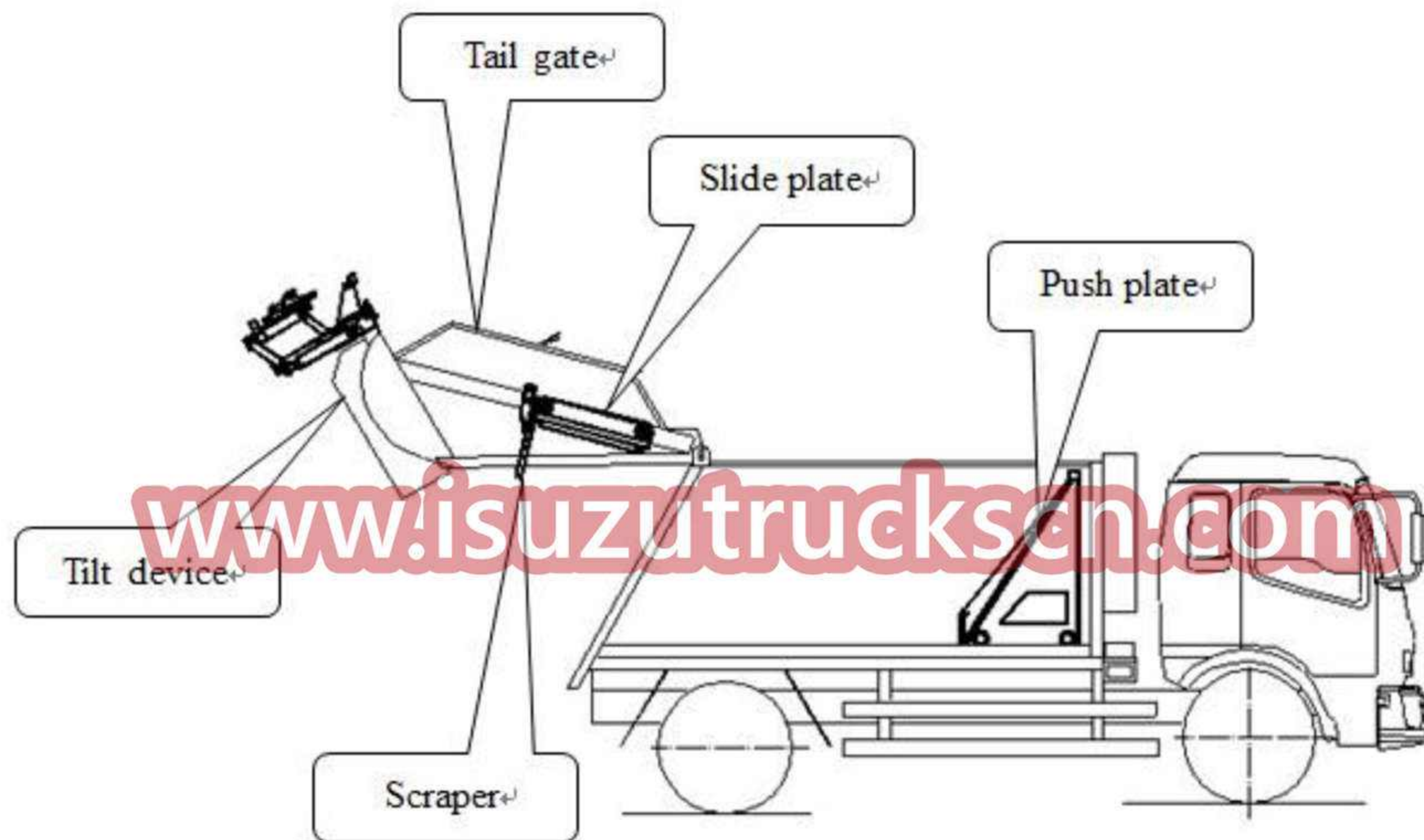

Front View: Hydraulic control system



Electric Control Box
(In cabin)

Hydraulic Control Joysticks
(At drive side)



Electric Control Box
(In cabin)

Hydraulic Control Joysticks
(At drive side)



Front View: garbage collection system and waste water collecting bins



Garbage collection system

Waste water collecting bins

POWERSTAR

Tail Gate Assembly



Slide Plate Assembly



www.isuzutruckscn.com

Scraper Assembly



Push Plate Assembly



Tilting Device Assembly
(Tilting double 240L
garbage bin same time)





(Main Control Box in Cabin)



www.isuzutruckscn.com

(Rear Control Box at two sides of the hopper)

Chapter 4, Garbage Compactor Truck Working Principles

The operator should fully understand Whole Structure and Working Principle for ISUZU Garbage Compactor Truck before any operation. Only trained person can operate this vehicle properly and to prevent unnecessary accidents and equipment damage.

i ,How are the Garbage Compactor trucks working?

The ISUZU Garbage Compactor Truck makes use of the special power take off (PTO) to get power from the engine, and then transfer the power to the Gear Pump via drive axle so to rotate the pump. The pump start working to transfer hydraulic oil to cylinders through pipelines, and cylinders working to make all garbage trucks equipment working, including tailgate, push plate, slide plate, scraper and tilting device. And then realize all function of the garbage compactor truck.

ii ,What is the main component for truck?

The garbage compactor truck is refitted based on the ISUZU 4x2 LHD chassis. The refit part includes garbage collection assembly, actuator device and operation system.

- *Garbage collection assembly: Carbon steel material tanker body for garbage storage, with tailgate, tilting device, slide plate, scraper and push plate to realize garbage loading and unloading working.*
- *Actuator device: includes power take off, drive line, etc., which can pass the power from the chassis to the gear pump.*
- *Operation system: including Electric control system (Main control box in cabin & two Rear control box at two sides of tailgate) and Hydraulic Joystick control system, which helps come to all special functions' convert.*

iii, How to operate garbage compactor trucks? (Very Important)

1.1 Ready to work

(If idle for a long time, please keep the truck engine run for a few minutes. Also, should ensure fuel tank and water tank are enough.)

➤ **Step 1**

Thoroughly check the compactor to make sure working environment is good. Then start the truck engine. Press the Clutch Pedal, meanwhile press the PTO (Power Take Off) to Working Position.

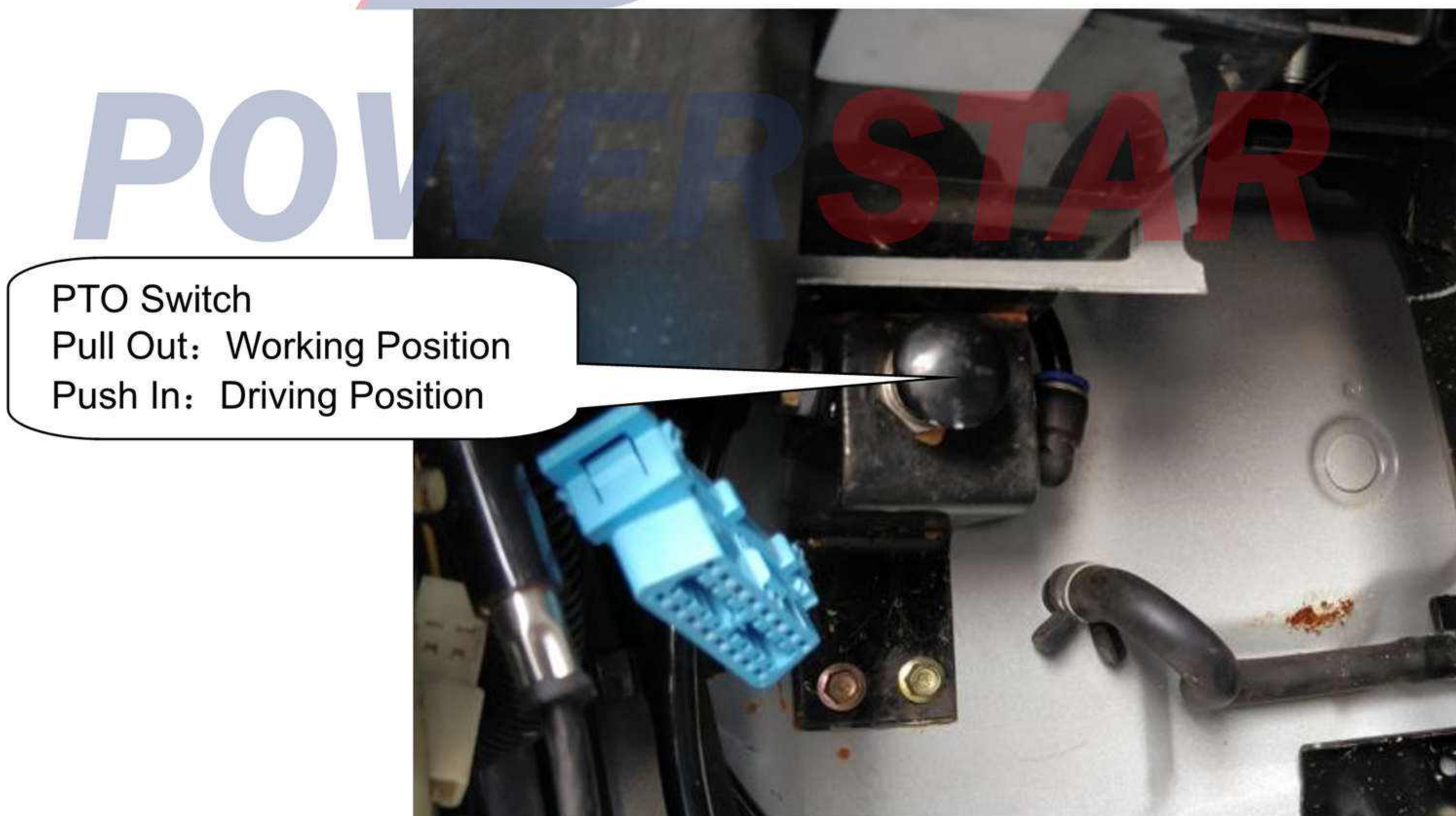

Please Note: Please keep the PTO at Driving Position while driving the truck!
Please does not operating the garbage compactor system while driving the truck!

www.isuzutruckscn.com

➤ **Step 2**

Make sure the working environment is safe. Then Starting the POWER BUTTON in the control box, turn the button to Loading

NOTE: No staying under Tail Gate

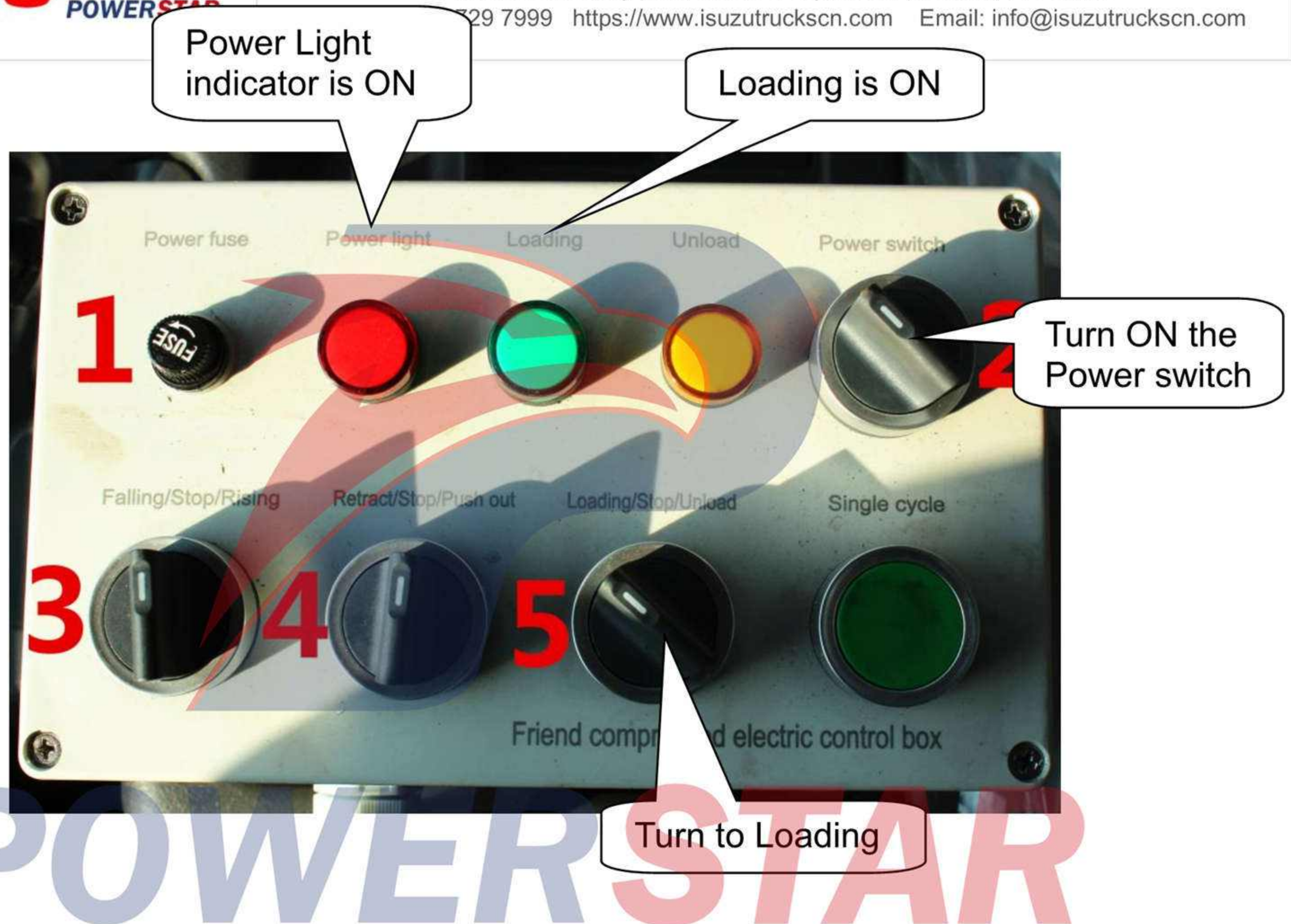

Switch 1: **Throttle** Manual / Foot / Automatic (Automatic is recommended)

Switch 2: Power Switch (Whole truck electric box working)

Switch 3: **Tailgate** Falling / Stop / Rising (Control Tailgate working)

Switch 4: **Push Plate** Retract / Stop / Push out (Control Push Plate working)

Switch 5: Working Model Loading / Stop / Unloading

➤ **Step 3**

Rear Control Box operates instruction.

Kindly refer to below picture to be familiar with the box panel

www.isuzutruckscn.com

Automatic operating system & Manual operating system available to you!



Automatic operating system

Third Button Turn to AUTOMATIC (main control box & rear control boxes)

Step 3.1.1

Second button turn to DOWN, the **tilt device** *down*, collecting the garbage from 240L bins;
Then turn to RISE, the **tilt device** *up*, the garbage down to the **Tail Gate** stuffer.

Turn to DOWN again to make tilt device reposition before the scraper working.

(How does this model garbage compactor truck tilting device working?)



Tilt Device DOWN



Tilt Device UP

Step 3.1.2

Press the Fourth button, compression single cycle (**little garbage at Stuffer**)

Press the Fifth button, compression continue cycle (**much garbage at Stuffer**)

Step 3.1.3

Press the Sixth button, when continue cycle compression finished.

NOTE: Press the First button when there is an emergency!

Step 3.1.4

Make the **tilt device** *STOP*, the truck is ready for next compression work.

Manual operating system

Third button turn to MANUAL (main control box & rear control box)

Step 3.2.1

Second button turn to DOWN, the **tilt device** down, collecting the garbage from 240L bins;
Then turn to RISE, the **tilt device** up, the garbage down to the **Tail Gate** stuffer.

Turn to **DOWN** again make **tilt device** reposition before the scraper working.

Step 3.2.2

Press the fourth button to make **slide plate** down.



Step 3.2.3

Press the First button to make the **scraper** closed to collect garbage.

Step 3.2.4

Press the Fifth button to make the **slide plate** upward

www.isuzutruckscn.com

Step 3.2.5

Press the Sixth button to make the **scraper** open

Step 3.2.6

Operate once again to collect and compress more garbage.

(NOTE: tilt device should be Stop every time before the scraper working)

➤ **Step 4**

NOTE: Only suggest to use MANUAL JOYSTICK when maintenance or emergency!

(Operation Joysticks with English version plate for operating guidance)

Control the manual joystick to work.

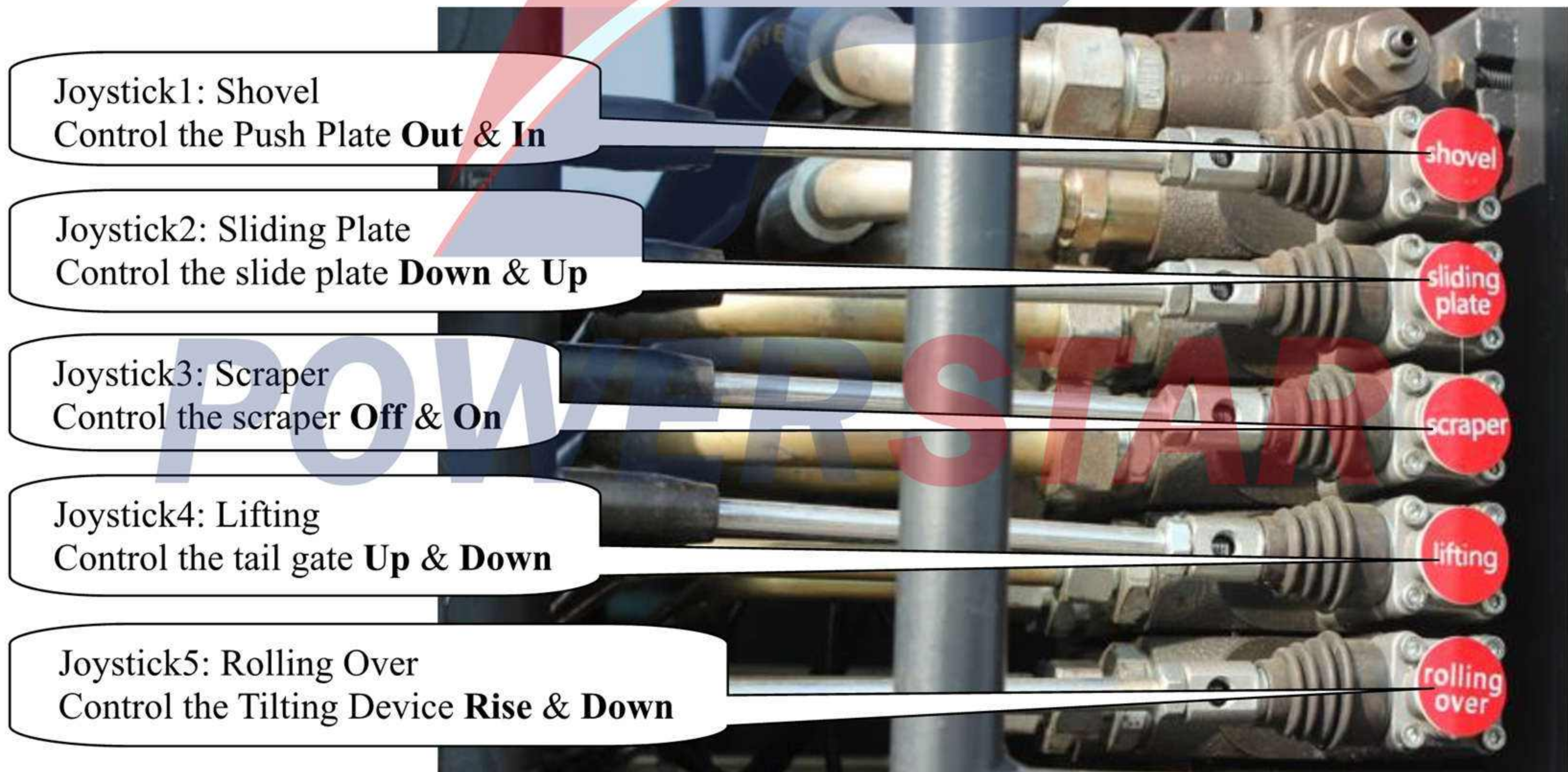

1.2 Dumping the garbage

➤ **Step 1**

Make sure **no staying under the tail gate**

(Please be sure for every compression work)

➤ **Step 2**

Turn the main control to Unload



POWERSTAR

➤ **Step 3**

Control (Switch3 or Joystick4) to make the **tail gate up**. Please reposition when tail gate rises completely.

Control Switch3 or Joystick4:
tail gate up



Control Switch4 or Joystick1:
push plate move out

➤ **Step 4**

www.isuzutrucks.cn

Control (Switch4 or Joystick1) to make the **push plate move out**.

➤ **Step 5**

Wait until all garbage discharged

➤ **Step 6**

Control (Switch4 or Joystick1) to make the **push plate** move in until reposition.

➤ **Step 7**

Control (Switch3 or Joystick4) to make the **tail gate** down. Please reposition all when **tail gate** down completely.

➤ **Step 8**

Drain out all the waste water produced by compressing work.



Waste Water Vents



Waste Water collection tank

www.isuzutruckscn.com

1.3 Cleaning the body

The engine must **flameout** when arrive at cleaning field.

➤ **Step 1**

Clean vehicle exterior.

Control (Switch3 or Joystick4) to make the **tail gate up**. Then cleaning the inside body.
Clean the **tail gate device** internal.

➤ **Step 2**

Add some lubrication on spindle to keep compactor work safety and smooth.

Garbage Compactor Truck Hydraulic Drawing:

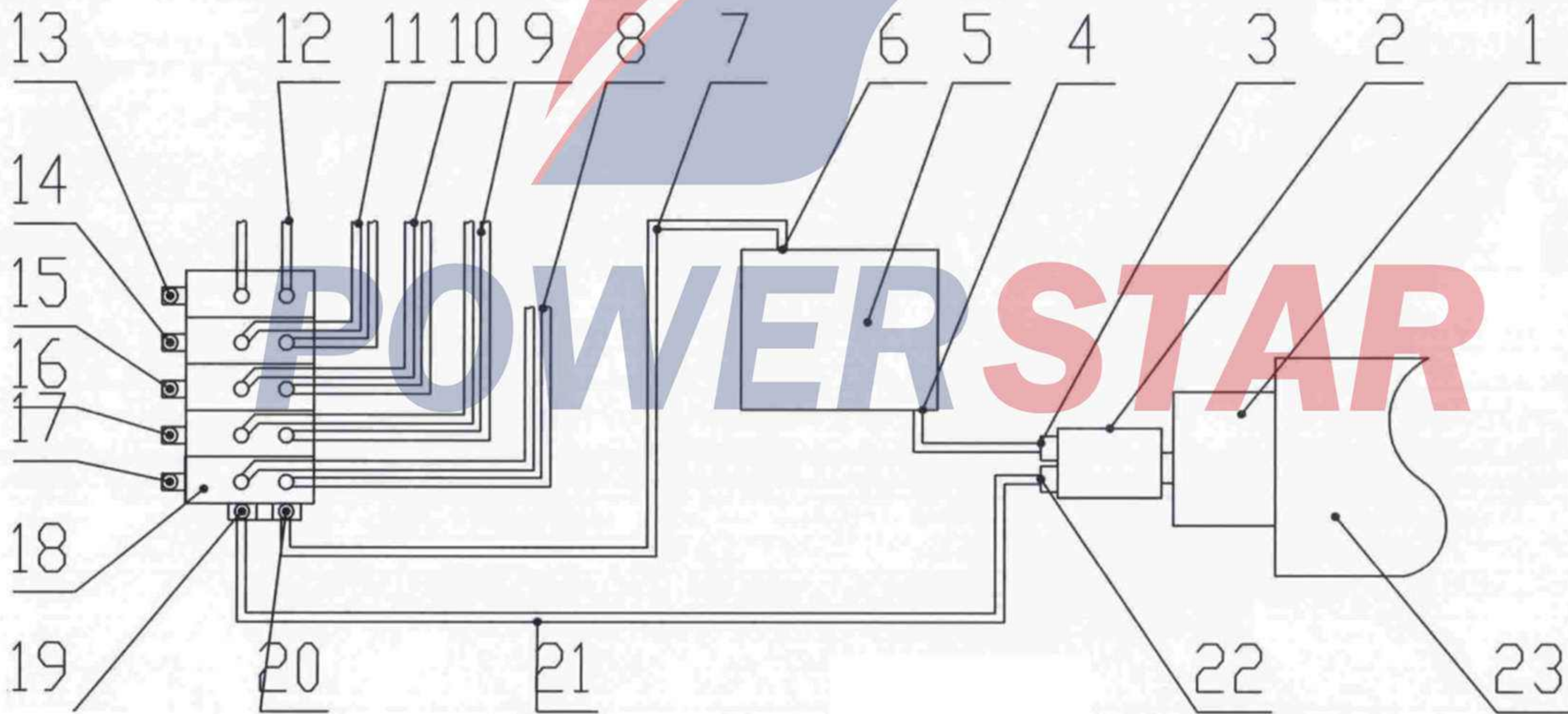

- | | | | | |
|-----------------------------------|------------------------------|----------------------------|------------------------------------|---------------------|
| 1、 PTO | 8、 Push Plate Oil Cylinder | 13、 Joystick 5 for Item 12 | 18、 Multi-way Valve | 23、 Chassis Gearbox |
| 2、 Oil Pump | 9、 Slide Plate Oil Cylinder | 14、 Joystick 4 for Item 11 | 19、 Oil Inlet for Multi-way Valve | |
| 3、 Inlet Pipe for Oil Pump | 10、 Scraper Oil Cylinder | 15、 Joystick 3 for Item 10 | 20、 Oil Outlet for Multi-way Valve | |
| 4、 Outlet pipe for Oil Tank | 11、 Tail Gate Oil Cylinder | 16、 Joystick 2 for Item 9 | 21、 Oil Pipeline | |
| 5、 Hydraulic Oil Tank | 12、 Tilt Device Oil Cylinder | 17、 Joystick 1 for Item 8 | 22、 Oil Inlet for Oil Pump | |
| 6、 Inlet Pipe for Multi-way Valve | | | | |
| 7、 Oil Pipeline | | | | |

Hydraulic Oil change suggestion: **YWZ-80T hydraulic oil or standard hydraulic oil**

For First Time: After 150-hour working, please change the hydraulic oil;

For Second Time: After half year working, please change the hydraulic oil;

Form Third Time: After every year working, please remember to change the hydraulic oil.

Chapter 5, Maintenance and Repair Instruction

Maintenance and Repair Instructions

The routine maintenance requirements and procedures for each subsystem of the compactor are described.

Every day

1、 Before maintenance work, the following things should be done firstly:

- a、 Turn off the PTO(power take-off) and speed-up switch, turn the manual joysticks to middle level.
- b、 Flameout the engine, take the key and put it into your pocket or other place to make sure it's safe.
- c、 Use the parking brake.
- d、 Put a sign wrote "under maintenance, please do not start" on the steering wheel.
- e、 Put chock under the wheels to make truck stability.

2、 Cleaning vehicle exterior, the inside and outside of the tilt device, the oil tank and pipe, all these daily working has purpose to prevent rust and to keep compactor ready for work anytime.

3、 Carefully examine the hydraulic system, including whether hydraulic oil at normal level, whether the hydraulic pipeline leak oil or not, which can protect the compactor truck and always keep the compactor ready to work anytime.

4、 Carefully check whether the electric system work normal or not, including the tail lights, the work indicating lamp etc.

5、 Carefully clean the compress lock at the rear of the truck. To keep compression work efficiently.

6、 Carefully check the entire compactor to inspect whether any warning signs and operating instruction sign fell off. Catch up on them when necessary.

7、Lubricate the whole pathway of the compressed garbage truck every day.

8、Carefully clean the **push plate** and surrounding of the oil tank.

Every week

1、Carefully inject butter or other lubrication to the spindles of the compactor, places are as below pictures:

- a、Lubricate the spindles of the tail gate
- b、Lubricate the cover of pivots of the scraper
- c、Lubricate the oil cylinder bearing of the scraper
- d、Lubricate the pathway of the slide plate
- e、Lubricate the all the connecting rod
- f、Lubricate the chassis by following the maintenance manual



www.isuzutruckscn.com

2、Carefully exam the compactor to check out whether any connection place need to fasten again.

Every month

1、Carefully exam all the pipes, find out whether there is any leakage. If there are, please exchange

it immediately.

- 2、 Carefully exam the compression cylinder and the scraper oil cylinder piston rod, find out whether they are all working normally.
- 3、 Carefully exam the push plate oil cylinder, find out whether it work normally.
- 4、 Carefully lubricate axles of the push plate to make it work smoothly and efficiently.
- 5、 Carefully lubricate the sideways of the push plate to make it work normally.

Every 6 month

- 1、 Carefully cleaning the air filter.
- 2、 Carefully cleaning the oil suction filter.
- 3、 Carefully replace the oil filter cartridge
- 4、 Carefully exam the entire body of the truck to find out if anything need improved. Such as any place rusting; is the framework still work normally etc.

Every 2 Year

- 1、 Cycle maintenance as mentioned above.
- 2、 Carefully clean fuel tank, replace the hydraulic oil.

www.isuzutruckscn.com

Maintenance of the hydraulic system

1、 Hydraulic oil tank

- a、 Fine filter of oil return pipe: First exchange happened after 50 hours use, then every 250hours. When there is something wrong with the main parts of the hydraulic system also should change it.
- b、 Respirator: Keep the respirator clean, non-stop and correctly installed to make the air can goes inside the oil tank freely. Exchange the respirator every 6 month. (the exchange time should be short when working at dirty environment for a long time.)
- c、 Hydraulic oil: First exchange happened after 150 hours use,
Second exchange happened after 6 month use,
Then every 12 months use.

NOTE: YWZ-80T hydraulic oil or standard hydraulic oil;

- d、 Oil outlet strainer: Should be cleaned every time exchange the oil. Replace it when necessary.

2、 Oil cylinder

- a、 Carefully exam the oil cylinder to find out whether there is leakage and noise or not every week.
- b、 Carefully check the oil tank, repair when there are scar on piston rod, repair all the scars in time to avoid any danger.

www.isuzutruckscn.com

Chapter 6, Troubleshooting

Failure	Cause	Solution
Oil leakage happened on oil cylinder piston rod	1、 The damage of the sealing ring 2、 There are scars on the surface of the piston rod	1、 Carefully exam the guide sleeve and replace the sealing ring 2、 Replace the parts.
Piston rod move slowly	1、 Some air mixed in the hydraulic cylinder or in the hydraulic oil 2、 There are no hydraulic oil in the tank or oil level is too low to work normally. 3、 Viscosity of hydraulic oil failing standard 4、 Stoppage of the oil inlet/outlet strainer 5、 Stoppage or limiting of the hydraulic oil in system 6、 Leakage of the oil suction pipe 7、 Abrasion of the oil pump 8、 Abrasion of some parts 9、 Adjustment of the parts are not proper. 10、 Pressure valve is too dirty 11、 Overload of the system work	1、 Eliminate all the air 2、 Inject some hydraulic oil and carefully check the system. 3、 Replace hydraulic oil to recommended ones. 4、 Carefully clean or replace it, and find out the polluted reason 5、 Carefully check the oil pipes and clean them. 6、 Repair or replace it 7、 Repair or replace it 8、 Carefully check the pump, valve and oil cylinder, find the abrasion part and repair or replace it. 9、 Refer to the technical manual to adjust properly 10、 Carefully clean it 11、 Refer to the technical manual to load properly. 12、 Reconnect the oil pipe properly

	<p>12、 Improper oil pipe connection</p> <p>13、 Oil pump not work</p> <p>14、 The hydraulic oil temperature is too low</p> <p>15、 The engine's revolving speed is not enough</p>	<p>13、 Carefully check the PTO</p> <p>14、 The viscosity is too high and should be adjust oil temperature to working level</p> <p>15、 Adjust to proper level</p>
Hydraulic cylinder pushing is powerless	<p>1、 Damage of the piston sealing</p> <p>2、 System pressures is too low (the overflow valve became imbalance)</p> <p>3、 Damage of the oil pump, System pressures is too low</p> <p>4、 Shortage of the hydraulic oil</p> <p>5、 Stoppage of the oil filter</p>	<p>1、 Carefully exam and replace the sealing element</p> <p>2、 Carefully exam and adjust the pressure of the overflow valve</p> <p>3、 Carefully exam and replace the oil pump</p> <p>4、 Carefully exam and fulfill the hydraulic oil</p> <p>5、 Carefully exam and replace the filter element</p>
Leakage of the oil pump	<p>1、 Damage of the sealing filter</p> <p>2、 The oil pipes are not sealed as required</p>	<p>1、 Carefully exam and replace the sealing ring</p> <p>2.1、 Carefully exam, tighten the joint</p> <p>2.2、 Replace the joint or add some sealant to seal the joint</p>

www.isuzutruckscn.com

<p>Blister exist in the hydraulic oil</p>	<ol style="list-style-type: none"> 1、 Oil level in the tank is too low 2、 There is water in the hydraulic oil 3、 Leakage of the pipe between the oil tank and the pump 4、 Hydraulic hose is kinked or squished, and limit the flow of the oil 5、 Have not choose the right hydraulic oil 6、 Abrasion of the sealing parts in oil pump axle 	<ol style="list-style-type: none"> 1、 Adjust the oil to required level. Carefully exam the leakage of the system. 2、 Exchange new hydraulic oil 3、 Fasten the joint or exchange suction pipe 4、 Replace the oil pipe 5、 Exchange to the recommend oil 6、 Carefully clean or replace it.
<p>Oil pump is too noise while working</p>	<ol style="list-style-type: none"> 1、 The hydraulic oil viscosity is too high 2、 Speed of the oil pump is too high 3、 Suction pipe is blocked or extrusion 4、 The oil tank's respirator is blocked 5、 Primary oil filter is blocked 6、 Parts sticking to each other 7、 There are air in the hydraulic oil 8、 Hydraulic oil level is too low 9、 Parts of the oil pump is abrasion 	<ol style="list-style-type: none"> 1、 Change low viscosity oil 2、 Adjust the oil pump's speed to required level. 3、 Cleaning or exchange the suction pipe 4、 Open the respirator , Carefully wash to clean it. 5、 Cleaning the filter screen 6、 Carefully repair the sticking parts, cleaning all of them, and replace when necessary 7、 Carefully check the system, replace the suction pipe and sealing parts. 8、 Adjust to proper level 9、 Repair the oil pump and find out the reason

<p>Leakage of oil cylinder</p>	<ol style="list-style-type: none"> 1、 Damage of the cylinder 2、 Damage of the parts of piston valve 3、 Parts of the oil cylinder is loose 4、 Damage of the piston rod 	<ol style="list-style-type: none"> 1、 Replace the cylinder and find out why it damaged 2、 repair or replace the piston valve, find out the reason 3、 Fasten the parts until no leakage 4、 Carefully exam, exchange it when necessary
<p>Hydraulic oil temperature is too high</p>	<ol style="list-style-type: none"> 1、 Use the control valve for a long time 2、 Hydraulic oil is not proper 3、 The revolving speed is high 4、 The inside leakage 	<ol style="list-style-type: none"> 1、 The manual joystick should reposition when not use 2、 Exchange to proper oil 3、 Adjust to proper level 4、 Carefully check the pump, valve and oil cylinder to find out reason, then repair it.

www.isuzutruckscn.com